

MAX[®]

TA551A/16-11(CE)

PNEUMATIC STAPLER

PNEUMATISCHER HEFTER

AGRAFEUSE PNEUMATIQUE

AGGRAFFATRICE PNEUMATICA

MÁQUINA GRAPADORA NEUMÁTICA



OPERATING and MAINTENANCE MANUAL
BETRIEBSANLEITUNG
MANUEL D'UTILISATION et D'ENTRETIEN
MANUALE DI FUNZIONAMENTO E MANUTENZIONE
MANUAL DE OPERACIONES Y MANTENIMIENTO



WARNING

BEFORE USING THIS TOOL, STUDY THIS MANUAL TO ENSURE SAFETY WARNING AND INSTRUCTIONS.

KEEP THESE INSTRUCTIONS WITH THE TOOL FOR FUTURE REFERENCE.



ACHTUNG

LESEN SIE VOR INBETRIEBNAHME DES GERÄTES DIE GEBRAUCHS- UND SICHERHEITSHINWEISE. BITTE BEWAHREN SIE DIE GEBRAUCHS- UND SICHERHEITSHINWEISE AUF, DAMIT SIE AUCH SPÄTER EINGESEHEN WERDEN KÖNNEN.



AVERTISSEMENT

AVANT D'UTILISER CET OUTIL, LIRE CE MANUEL ET LES CONSIGNES DE SECURITE AFIN DE GARANTIR UN FONCTIONNEMENT SUR.

CONSERVER CE MANUEL EN LIEU SUR AVEC L'OUTIL AFIN DE POUVOIR LE CONSULTER ULTERIEUREMENT.



ATTENZIONE

PRIMA DI USARE QUESTA MACCHINA, STUDIARE IL MANUALE PER PRENDERE ATTO DEGLI AVVERTIMENTI E DELLE ISTRUZIONI PER LA SICUREZZA.

TENERE QUESTE ISTRUZIONI INSIEME ALLO STRUMENTO PER CONSULTAZIONI FUTURE.



ATENCIÓN

PARA EVITAR GRAVES DAÑOS PERSONALES O EN LA PROPIEDAD.

ANTES DE EMPLEAR LA HERRAMIENTA, LEER CON ATENCIÓN Y COMPRENDER LOS SIGUIENTES INSTRUCCIONES DE SEGURIDAD.

ENGLISH	Page 3 to 14	Page
DEUTSCH	Page 15 to 26	Page
FRANÇAIS	Page 27 to 38	Page
ITALIANO	Page 39 to 50	Page
ESPAÑOL	Page 51 to 62	Page

DEFINITIONS OF SIGNAL WORDS

- WARNING:** Indicates a potentially hazardous situation which, if not avoided, could result in death or serious injury.
- CAUTION:** Indicates a potentially hazardous situation which, if not avoided, may result in minor or moderate injury.
- NOTE:** Emphasizes essential information.

DEFINITIONEN DER HINWEISBEZEICHNUNGEN

- ACHTUNG!** Zeigt eine eventuell gefährliche Situation an, die den Tod oder schwere Verletzungen zur Folge haben könnte, wenn sie nicht vermieden wird.
- VORSICHT!** Zeigt eine eventuell gefährliche Situation an, die leichte oder mittelschwere Verletzungen zur Folge haben könnte, wenn sie nicht vermieden wird.
- HINWEIS:** Hebt wichtige Informationen hervor.

DÉFINITIONS DES DIFFÉRENTS DEGRÉS D' AVERTISSEMENTS

- AVERTISSEMENT** Indique une situation éventuellement dangereuse qui, si elle n'est pas contournée, pourrait provoquer la mort ou des blessures sérieuses.
- ATTENTION** Indique une situation éventuellement dangereuse qui, si elle n'est pas contournée, pourrait provoquer des blessures légères à moyennement sérieuses.
- REMARQUE** Souligne des informations importantes.

DEFINIZIONE DELLE INDICAZIONI DI AVVERTIMENTO

- ATTENZIONE:** Indica l'eventualità che possa verificarsi una situazione pericolosa, la quale se non viene evitata, può risultare letale o provocare gravi lesioni.
- AVVERTENZA:** Indica l'eventualità che possa verificarsi una situazione pericolosa, la quale se non viene evitata, può provocare lesioni di lieve o media entità.
- NOTA:** Evidenzia informazioni importanti.

DEFINICIÓN DE LAS INDICACIONES DE ADVERTENCIA

- ¡ATENCIÓN!** Indica una situación potencialmente peligrosa que podría causar la muerte o graves lesiones si no se evita.
- ¡PRECAUCIÓN!** Indica una situación potencialmente peligrosa que podría causar lesiones menos graves o leves si no se evita.
- NOTA:** Resalta informaciones importantes.

INDEX

1. SAFETY INSTRUCTIONS 3

2. SPECIFICATIONS & TECHNICAL DATA 7

3. AIR SUPPLY AND CONNECTIONS 8

4. INSTRUCTIONS FOR OPERATION 10

5. MAINTENANCE 14

6. STORAGE 14

7. TROUBLESHOOTING/REPAIRS 14



BEFORE USING THIS TOOL, STUDY THIS MANUAL TO ENSURE SAFETY WARNING AND INSTRUCTIONS.

WARNING KEEP THESE INSTRUCTIONS WITH THE TOOL FOR FUTURE REFERENCE.

1. SAFETY INSTRUCTIONS



WARNING

TO AVOID SEVERE PERSONAL INJURY OR PROPERTY DAMAGE

BEFORE USING THE TOOL, READ CAREFULLY AND UNDERSTAND THE FOLLOWING "SAFETY INSTRUCTIONS". FAILURE TO FOLLOW WARNINGS COULD RESULT IN DEATH OR SERIOUS INJURY.

PRECAUTIONS ON USING THE TOOL



1. WEAR SAFETY GLASSES OR GOGGLES

Danger to the eyes always exists due to the possibility of dust being blown up by the exhausted air or of a fastener flying up due to the improper handling of the tool. For these reasons, safety glasses or goggles shall always be worn when operating the tool.

The employer and/or user must ensure that proper eye protection is worn. Eye protection equipment must conform to the requirements of Council Directive 89/686/EEC of 21 DEC. 1989 (the American National Standards Institute, ANSI Z87.1) and provide both frontal and side protection.

The employer is responsible to enforce the use of eye protection equipment by the tool operator and all other personnel in the work area.

NOTE: Non-side shielded spectacles and face shields alone do not provide adequate protection.



2. EAR PROTECTION MAY BE REQUIRED IN SOME ENVIRONMENTS

As the working condition may include exposure to high noise levels which can lead to hearing damage, the employer and user should ensure that any necessary hearing protection is provided and used by the operator and others in the work area.



3. DO NOT USE ANY POWER SOURCE EXCEPT AN AIR COMPRESSOR

The tool is designed to operate on compressed air. Do not operate the tool on any other highpressure gas, combustible gases (e.g., oxygen, acetylene, etc.) since there is the danger of an explosion. For this reason, absolutely do not use anything other than an air compressor to operate the tool.



4. OPERATE WITHIN THE PROPER AIR PRESSURE RANGE

The tool is designed to operate within an air pressure range of 5 to 7 bar (70 to 100 p.s.i.). The pressure should be adjusted to the type of the work being fastened. The tool shall never be operated when the operating pressure exceeds 8 bar (120 p.s.i.).

Never connect the tool to air pressure which potentially exceeds 14 bar (200 p.s.i.) as the tool can burst.

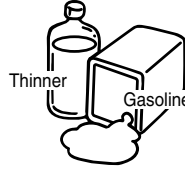

5. DO NOT OPERATE THE TOOL NEAR A FLAMMABLE SUBSTANCE

Never operate the tool near a flammable substance (e.g., thinner, gasoline, etc.). Volatile fumes from these substances could be drawn into the compressor and compressed together with the air and this could result in an explosion.

6. NEVER USE THE TOOL IN AN EXPLOSIVE ATMOSPHERE

Sparks from the tool may ignite atmospheric gases, dust or other combustible materials.

7. DO NOT USE A WRONG FITTINGS

The connector on the tool must not hold pressure when air supply is disconnected. If a wrong fitting is used, the tool can remain charged with air after disconnecting and thus will be able to drive a fastener even after the air line is disconnected, possibly causing injury.



8. DISCONNECT THE AIR SUPPLY AND EMPTY THE MAGAZINE WHEN THE TOOL IS NOT IN USE

Always disconnect the air supply from the tool and empty the magazine when operation has been completed or suspended, when unattended, moving to a different work area, adjusting, disassembling, or repairing the tool, and when clearing a jammed fastener.



9. INSPECT SCREW TIGHTNESS

Loose or improperly installed screws or bolts cause accidents and tool damage when the tool is put into operation. Inspect to confirm that all screws and bolts are tight and properly installed prior to operating the tool.



10. DO NOT TOUCH THE TRIGGER UNLESS YOU INTEND TO DRIVE A FASTENER

Whenever the air supply is connected to the tool, never touch the trigger unless you intend to drive a fastener into the work. It is dangerous to walk around carrying the tool with the trigger pulled, and this and similar actions should be avoided.



11. NEVER POINT THE DISCHARGE OUTLET TOWARD YOURSELF AND OTHER PERSONNEL

If the discharge outlet is pointed toward people, serious accidents may be caused when misfiring. Be sure the discharge outlet is not pointed toward people when connecting and disconnecting the hose, loading and unloading the fasteners or similar operations.

12. USE SPECIFIED FASTENERS (SEE PAGE 7)

The use of fasteners other than specified fasteners will cause the tool malfunction. Be sure to use only specified fasteners when operating the tool.

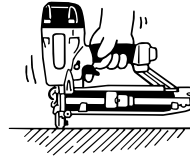

13. PLACE THE DISCHARGE OUTLET ON THE WORK SURFACE PROPERLY

Failure to place the discharge outlet of the nose in a proper manner can result in a fastener flying up and is extremely dangerous.



14. KEEP HANDS AND BODY AWAY FROM THE DISCHARGE OUTLET

When loading and using the tool, never place a hand or any part of body in fastener discharge area of the tool. It is very dangerous to hit the hands or body by mistake.



15. DO NOT DRIVE FASTENERS CLOSE TO THE EDGE AND CORNER OF THE WORK AND THIN MATERIAL

The workpiece is likely to split and the fastener could fly free and hit someone.

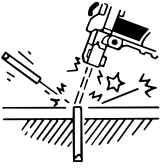

16. DO NOT DRIVE FASTENERS ON TOP OF OTHER FASTENERS

Driving fasteners on the top of other fasteners may cause deflection fasteners which could cause injury.

17. REMOVING THE FASTENERS AFTER COMPLETING OPERATION

If fasteners are left in the magazine after the completion of operation, there is the danger of a serious accident occurring prior to the resumption of operation, should the tool be handled carelessly, or when connecting the air fitting. For this reason, always remove all fasteners remaining in the magazine after completion of the operation.

18. CHECK OPERATION OF THE CONTACT TRIP MECHANISM FREQUENTLY IN CASE OF USING A CONTACT TRIP TYPE TOOL

Do not use the tool if the trip is not working correctly as accidental driving of a fastener may result. Do not interfere with the proper operation of the contact trip mechanism.

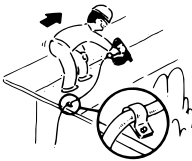

19. WHEN USING THE TOOL OUTSIDE OR ELEVATED PLACE

When fastening roofs or similar slanted surface, start fastening at the lower part and gradually work your way up. Fastening backward is dangerous as you may lose your foot place.

Secure the hose at a point close to the area you are going to drive fasteners. Accidents may be caused due to the hose being pulled inadvertently or getting caught.

20. NEVER USE THE TOOL IF ANY PORTION OF THE TOOL CONTROLS (e.g., TRIGGER, CONTACT ARM) IS INOPERABLE, DISCONNECTED, ALTERED OR NOT WORKING PROPERLY

21. NEVER ACTUATE THE TOOL INTO FREE SPACE

This will avoid any hazard caused by free flying fasteners and excessive strain of the tool.

22. ALWAYS ASSUME THAT THE TOOL CONTAINS FASTENERS

23. RESPECT THE TOOL AS A WORKING IMPLEMENT

24. NO HORSEPLAY

25. NEVER LOAD THE TOOL WITH FASTENERS WHEN ANY ONE OF THE OPERATING CONTROLS (e.g., TRIGGER, CONTACT ARM) IS ACTIVATED

26. WEAR THE GLOVES DEPENDING ON THE WORKING CONDITION

27. WHEN DISPOSING THE MACHINE OR ITS PARTS, FOLLOW THE RELEVANT NATIONAL RULES

OBSERVE THE FOLLOWING GENERAL CAUTION IN ADDITION TO THE OTHER WARNINGS CONTAINED IN THIS MANUAL

- Do not use the tool as a hammer.
- Always carry the tool by the grip, never carry the tool by the air hose.
- The tool must be used only for the purpose it was designed.
- Never remove, tamper with the operating controls (e.g., TRIGGER, CONTACT ARM)
- Keep the tool in a dry place out of reach of children when not in use.
- Do not use the tool without Safety Warning label.
- Do not modify the tool from original design or function without approval by MAX CO., LTD.

2. SPECIFICATIONS AND TECHNICAL DATA

1. NAME OF PARTS

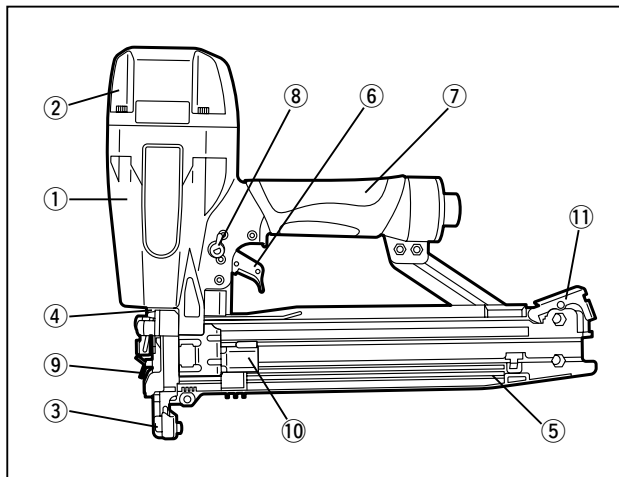

- ① Frame
- ② Cylinder Cap
- ③ Contact Arm
- ④ Nose
- ⑤ Magazine
- ⑥ Trigger
- ⑦ Grip
- ⑧ Trigger Lock Dial
- ⑨ Staple Removal Lever
- ⑩ Pusher
- ⑪ Click Lever

2. TOOL SPECIFICATIONS

PRODUCT NO.	TA551A/16-11 (CE)
HEIGHT	288.5 mm (11-3/8")
WIDTH	84 mm (3-1/4")
LENGTH	356 mm (14")
WEIGHT	2.2 kg (4.9 lbs.)
RECOMMENDED OPERATING PRESSURE	5 to 7 bar (70 to 100 p.s.i.)
LOADING CAPACITY	157 Staples
AIR CONSUMPTION	1.1 ℓ (0.039 ft ³) at 7 bar (100 p.s.i.) operating pressure

* The machine has been compactly designed in order to improve operating weight balance.

3. FASTENER SPECIFICATIONS

PRODUCT NO.	TA551A/16-11 (CE)
CROWN	11 mm (7/16")
LENGTH	25 to 51 mm (1" to 2")
WIDTH	1.57 mm (0.062")
THICKNESS	1.40 mm (0.055")
GAUGE	16

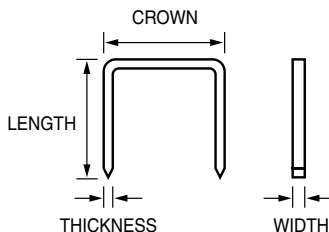

TOOL AIR FITTINGS:

This tool uses a 1/4" N.P.T. male plug. The inside diameter should be 7mm (.28") or larger. The fitting must be capable of discharging tool air pressure when disconnected from the air supply.

RECOMMENDED OPERATING PRESSURE:

5 to 7 bar (70 to 100 p.s.i.). Select the operating air pressure within this range for best fastener performance.

DO NOT EXCEED 8 bar (120 p.s.i.).

4. TECHNICAL DATA

1 NOISE

A-weighted single-event sound power level
----- LWA, 1s, d 93.78 dB

A-weighted single-event emission sound pressure level at work station
----- LpA, 1s, d 86.64 dB

These values are determined and documented in accordance to EN12549 : 1999.

2 VIBRATION

Vibration characteristic value = 3.6 m/s²
These values are determined and documented in accordance to ISO 8662-11.

This value is a tool-related characteristic value and does not represent the influence to the hand-arm-system when using the tool. An influence to the hand-arm-system when using the tool will, for example, depend on the gripping force, the contact pressure force, the working direction, the adjustment of mains supply, the workpiece, the workpiece support.



5. APPLICATIONS

- * General construction works including siding, decking, panel sheathing
- * Crating
- * Making wooden pallets

3. AIR SUPPLY AND CONNECTIONS



WARNING

Read section titled "SAFETY INSTRUCTIONS".



DO NOT USE ANY POWER SOURCE EXCEPT AN AIR COMPRESSOR

The tool is designed to operate on compressed air. Do not operate the tool on any other highpressure gas, combustible gases (e.g., oxygen, acetylene, etc.) since there is the danger of an explosion. For this reason, absolutely do not use anything other than an air compressor to operate the tool.



OPERATE WITHIN THE PROPER AIR PRESSURE RANGE

The tool designed to operate within an air pressure range of 5 to 7 bar (70 to 100 p.s.i.).

The pressure should be adjusted to the type of the work being fastened. The tool shall never be operated when the operating pressure exceeds 8 bar (120 p.s.i.).

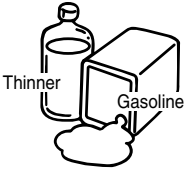

DO NOT OPERATE THE TOOL NEAR A FLAMMABLE SUBSTANCE

Never operate the tool near a flammable substance (e.g., thinner, gasoline, etc.). Volatile fumes from these substances could be drawn into the compressor and compressed together with the air and this could result in an explosion.

DO NOT USE A WRONG FITTINGS

The connector on the tool must not hold pressure when air supply is disconnected. If a wrong fitting is used, the tool can remain charged with air after disconnecting and thus will be able to drive a fastener even after the air line is disconnected, possibly causing injury.



DISCONNECT THE AIR SUPPLY AND EMPTY THE MAGAZINE WHEN THE TOOL IS NOT IN USE

Always disconnect the air supply from the tool and empty the magazine when operation has been completed or suspended, when unattended, moving to a different work area, adjusting, disassembling, or repairing the tool, and when clearing a jammed fastener.

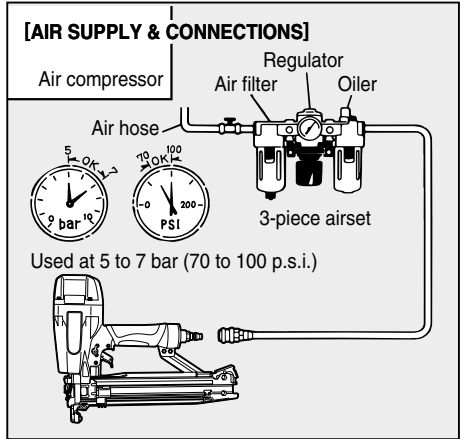

FITTINGS: Install a male plug on the tool which is free flowing and which will release air pressure from the tool when disconnected from the supply source.

HOSES: Hose has a min. ID of 6 mm (1/4") and max. length of no more than 5 meters (17"). The supply hose should contain a fitting that will provide "quick disconnecting" from the male plug on the tool.

SUPPLY SOURCE: Use only clean regulated compressed air as a power source for the tool.

3-PIECE AIRSET (Air filter, Regulator, Oiler): Refer to TOOL SPECIFICATIONS for setting the correct operating pressure for the tool.

NOTE: A filter will help to get the best performance and minimum wear from the tool because dirt and water in the air supply are major causes of wear in the tool. Frequent, but not excessive, lubrication is required for the best performance. Oil added thru the air line connection will lubricate the internal parts.

4. INSTRUCTIONS FOR OPERATION

Read section titled “SAFETY INSTRUCTIONS”.

1. BEFORE OPERATION

Check the following prior operation.

- ① Wear Safety Glasses or Goggles.
- ② Do not connect the air supply.
- ③ Inspect screw tightness.
- ④ Check operation of the contact arm & trigger if moving smoothly.
- ⑤ Connect the air supply.
- ⑥ Check the air-leakage. (The Tool must not have the air-leakage.)
- ⑦ Hold the Tool with finger-off the trigger, then push the contact arm against the work-piece. (The tool must not operate.)
- ⑧ Hold the Tool with contact arm free from work-piece and pull the trigger. (The Tool must not operate.)
- ⑨ Disconnect the air supply.



2. OPERATION

Wear safety glasses or goggles. Danger to the eyes always exists due to the possibility of dust being blown up by the exhausted air or of a fastener flying up due to the improper handling of the tool. For these reasons, safety glasses or goggles shall always be worn when operating the tool.

The employer and/or user must ensure that proper eye protection is worn. Eye protection equipment must conform to the requirements of Council Directive 89/686/EEC of 21 DEC. 1989 (the American National Standards Institute, ANSI Z87.1) and provide both frontal and side protection.

The employer is responsible to enforce the use of eye protection equipment by the tool operator and all other personnel in the work area.

NOTE: Non-side shielded spectacles and face shields alone do not provide adequate protection.



Keep hands and body away from the discharge outlet when driving the fasteners because of dangerous of hitting the hands or body by mistake.

STAPLE LOADING

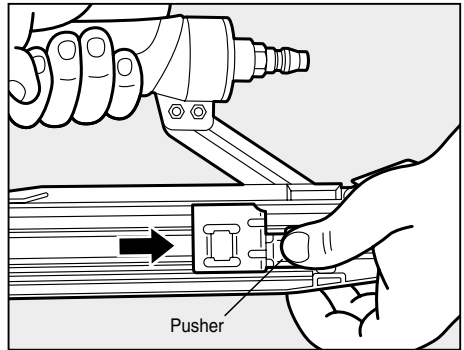

- ① Pull pusher back into “locked” position.

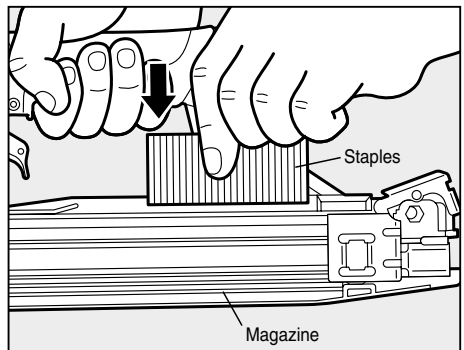

- ② Insert the staples into the magazine.

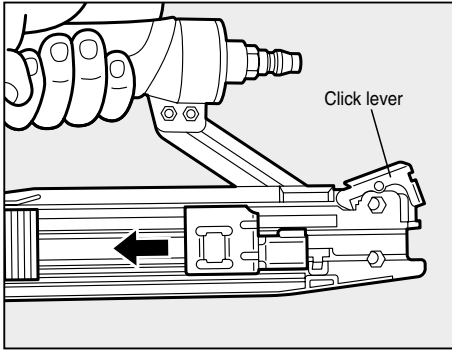

- ③ Hold the click lever and put back the pusher.

TEST OPERATION

- ① Adjust the air pressure at 5 bar (70 p.s.i.) and connect the air supply.
- ② Without touching the trigger, depress the contact arm against the work-piece.
Pull the trigger. (The tool must fire the fastener.)
- ③ With the tool off the work-piece, pull the trigger.
Then depress the contact arm against the work-piece. (The tool must fire the fastener.)
- ④ Adjust the air pressure as much as the lowest possible according to the length of fastener and the hardness of work-piece.

MODEL IDENTIFICATION

CONTACT TRIP

The common operating procedure on "Contact Trip" tools is for the operator to contact the work to actuate the trip mechanism while keeping the trigger pulled, thus driving a fastener each time the work is contacted. This will allow rapid fastener placement on many jobs, such as sheathing, decking and pallet assembly.

All pneumatic tools are subject to recoil when driving fasteners. The tool may bounce, releasing the trip, and if unintentionally allowed to recontact the work surface with the trigger still actuated (finger still holding trigger pulled) an unwanted second fastener will be driven.

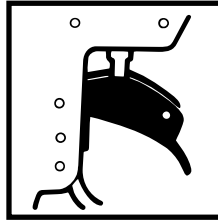

CONTACT TRIP

Identified by **BLACK TRIGGER**.

SEQUENTIAL TRIP

The Sequential Trip requires the operator to hold the tool against the work before pulling the trigger. This makes accurate fastener placement easier, for instance on framing, toe nailing and crating applications. The Sequential Trip allows exact fastener location without the possibility of driving a second fastener on recoil, as described under "Contact Trip".

The Sequential Trip Tool has a positive safety advantage because it will not accidentally drive a fastener if the tool is contacted against the work- or anything else-while the operator is holding the trigger pulled.

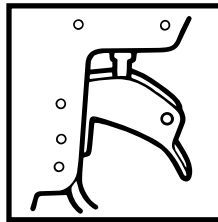

SEQUENTIAL TRIP

Identified by **ORANGE TRIGGER**.

DRIVING FASTENERS

**CONTACT FIRE OPERATION
(CONTACT TRIP)**

For contact fire operation, hold the trigger and depress the contact arm against the work surface.

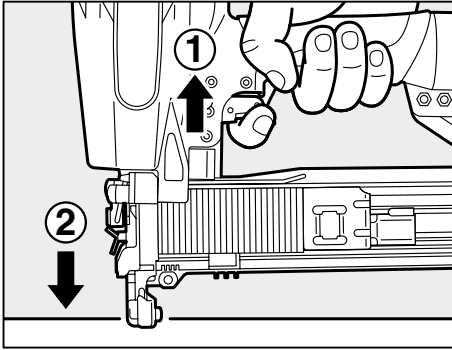

PROCEDURE

- ① Hold the trigger.
- ② Depress the contact arm.

**SINGLE FIRE OPERATION
(ANTI-DOUBLE FIRE MECHANISM AND
SEQUENTIAL TRIP)**

For single fire operation, depress the contact arm against the work surface and pull the trigger. Tool can not fire a second fastener until the trigger is released and tool can cycle.

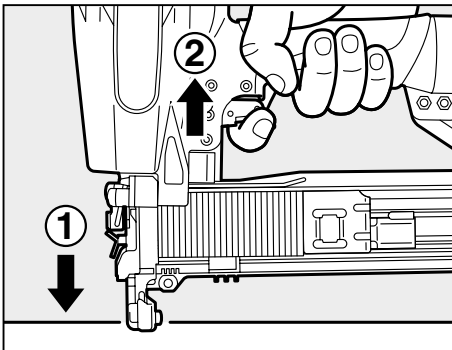

PROCEDURE

- ① Depress the contact arm.
- ② Pull the trigger.

DRIVING DEPTH ADJUSTMENT

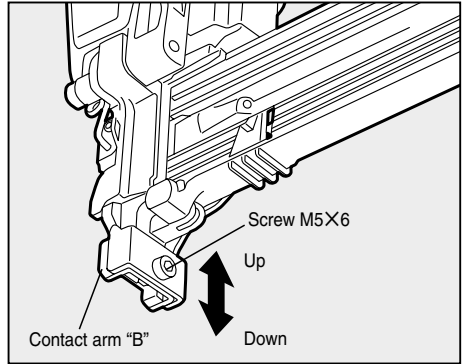
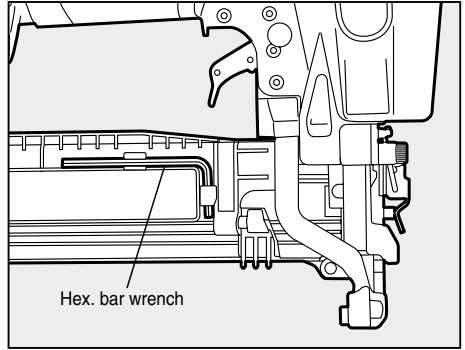

WARNING

ALWAYS disconnect air supply before making adjustment.

The driving depth adjustment is made by adjusting the contact arm "B".

- ① With air pressure set, drive a few staples into a representative material sample to determine if adjustment is necessary.
- ② If adjustment is required, disconnect air supply.
- ③ Take off hex. bar wrench set in the magazine. The screw M5X6 is loosened to allow the contact arm "B" to be moved up or down. If the tool is "OVER DRIVING" (the staples is driven below the work surface), the contact arm "B" should be moved down slightly. If staples "STICKING-OUT" (the staples is not flush with the work surface), the contact arm "B" should be moved up slightly.

- Tighten screw M5×6.
- ④ Reconnect air supply.

TRIGGER LOCK MECHANISM

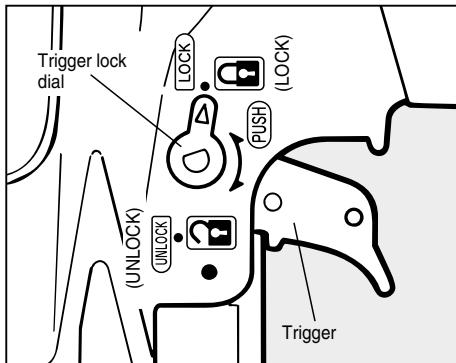

The tool is equipped with a trigger lock mechanism. Push and rotate the trigger LOCK to the trigger UNLOCK position before driving staples.

CLEARING JAMMED STAPLES

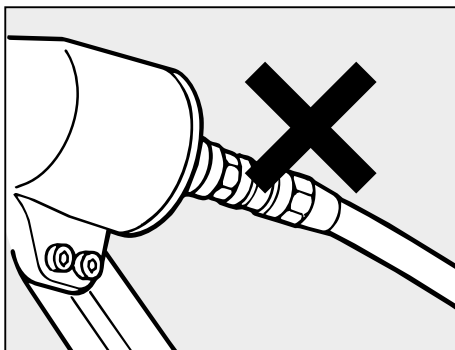

WARNING

ALWAYS disconnect air supply before clearing jammed fastener.

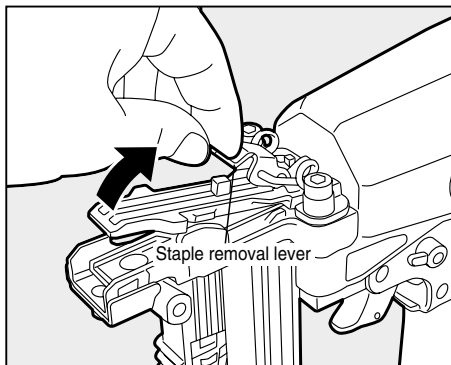

- ① Take out the staples from the inside of the magazine.
- ② Release the staple removal lever and open the door.
- ③ Remove staples that are jammed inside the nose by using a punch or slotted screw driver.

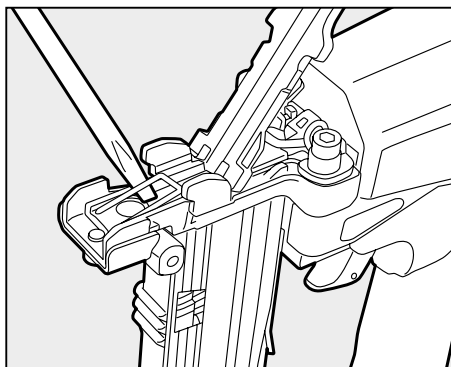

- ④ After removing the staples. Close the door and the staple removal lever.

5. MAINTENANCE

1 ABOUT PRODUCTION YEAR

This product bears production number at the lower part of the grip of the main body. The two digits of the number from left indicates the production year.

(Example)

0 8 8 2 6 0 3 5 D

↑
Year 2008

2 DO NOT FIRE THE STAPLER WHEN IT IS EMPTY

3 USE A 3-PIECE AIRSET

Failure to use a 3-piece airset allows the moisture and dirt inside compressor to pass into the tool directly. This causes rust and wear, and results in a poor operating performance. The hose length between airset and tool should be no longer than 5 m since a longer length results in a reduction in air pressure.

4 USE RECOMMENDED OIL

The velocite or turbine oil should be used to lubricate the tool. Upon completion of operations, place 2 or 3 drops of oil into the air plug inlet with the jet oiler. (Recommended Oil : ISO VG32)

5 INSPECT AND MAINTAIN DAILY OR BEFORE OPERATION



WARNING

Disconnect air supply and empty the magazine when inspecting or maintaining the tool.

- (1) Drain air line filter and compressor
- (2) Keep lubricator filled in air 3-pieces set
- (3) Clean filter element of air 3-pieces set
- (4) Tighten all screws
- (5) Keep contact arm moving smoothly

6. STORAGE

- 1 When not in use for an extended period, apply a thin coat of the lubricant to the steel parts to avoid rust.
- 2 Do not store the tool in a cold weather environment. Keep the tool in a warm area.
- 3 When not in use, the tool should be stored in a warm and dry place. Keep out of reach of children.
- 4 All quality tools will eventually require servicing or replacement of parts because of wear from the normal use.

7. TROUBLE SHOOTING/REPAIRS

The troubleshooting and/or repairs shall be carried out only by the MAX CO., LTD. authorised distributors or by other specialists.



Supplement to the operating instruction

According to the European Norm EN 792-13 the regulation is valid from 01.01.2001 that all fastener driving tools with contact actuation must be marked with the symbol "Do not use on scaffoldings, ladders" and they shall not be used for specific application for example:

- * when changing one driving location to another involves the use of scaffoldings, stairs, ladders or ladder alike constructions e.g. roof laths,
- * closing boxes or crates,
- * fitting transportation safety systems e.g. on vehicles and wagons.

TA551A/16-11

EXPLODED
VIEW AND SPARE
PARTS LIST

EINZELTEILDAR-
STELLUNG UND
ERSATZEILLISTE

SCHEMA ECLATE ET
LISTE DES PIECE
DE RECHANGE

ESPLOSO DEI
COMPONENTI DE
ELENCO DELLE
PARTI DI RICAMBIO

DESPIECE DE LA
MAQUINA Y LISTA
DE RECAMBIOS

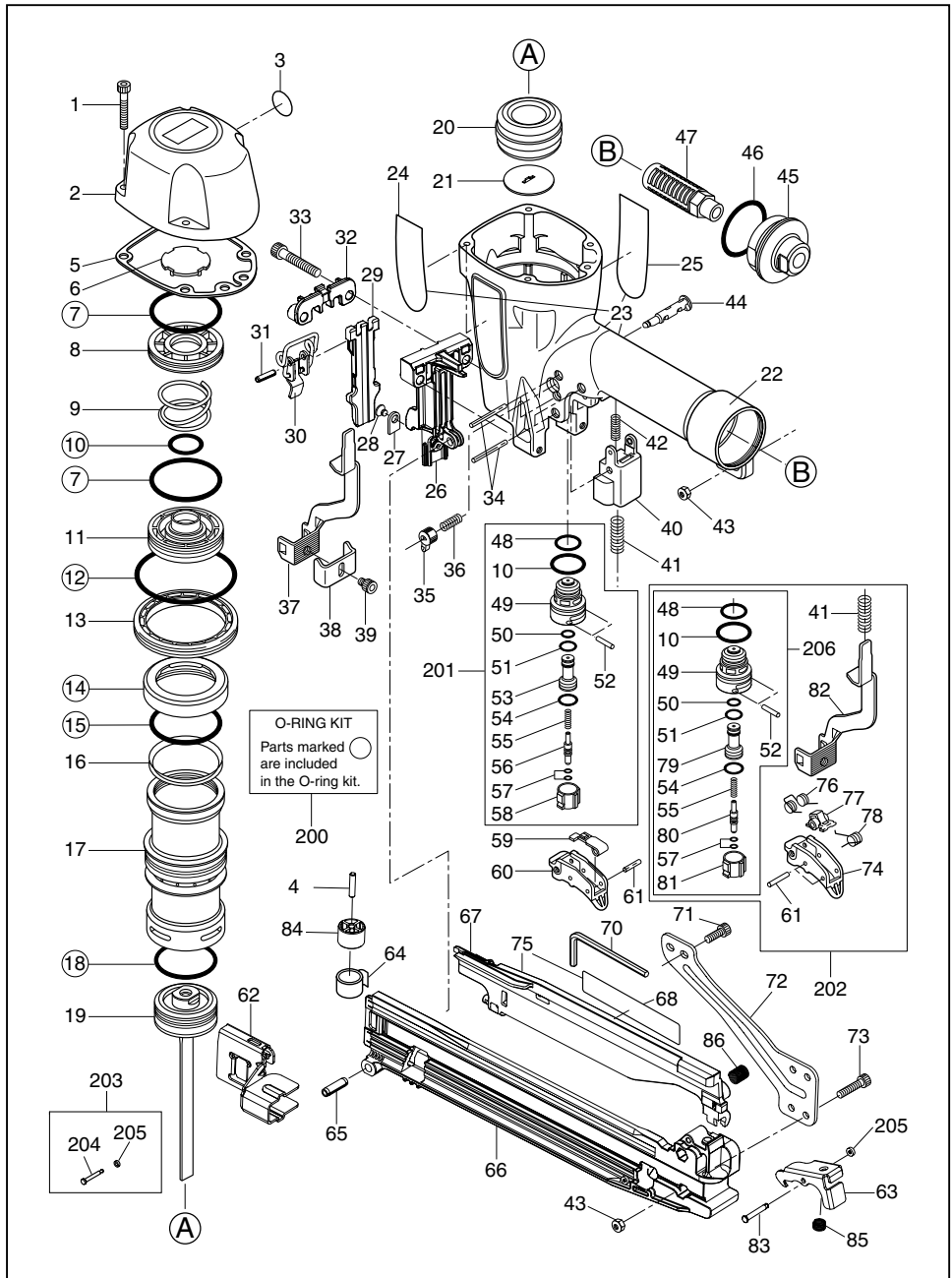

TA551A/16-11

ITEM NO.	PART NO.	MATERIAL	ENGLISH	DEUTSCH	FRANÇAIS	ITALIANO	ESPAÑOL
1	BB40470	Steel	SCREW M5x32	SCHRAUBE M5x32	VIS 5x32	VITE 5x32	TORNILLO M5x32
2	TA16996	Aluminum	CYLINDER CAP	ZYLINDERDEKEL	COUVERCLE DE CYLINDRE	COPERCHIO CILINDRO	CUBIERTA DE CILINDRO
3	CN35720	Polyethylene terephthalate	LABEL B (CE)	AUFKLEBER B (CE)	ÉTIQUETTE B (CE)	ETICHETTA B (CE)	ETIQUETA B (CE)
4	FF31535	Stainless steel	PARALLEL PIN 1535	PARALLELBOLZEN 1535	GOUILLE PARALLELE 1535	PERNO PARALLELO 1535	PERNO PARALLELO 1535
5	TA16997	Aluminum, Rubber	CYLINDER CAP SEAL	ZYLINDERDECKELDICHTUNG	JOINT DE COUVERCLE DE CYLINDRE	GUARNIZIONE COPERCHIO CILINDRO	JUNTA CUBIERTA DE CILINDRO
6	CN33838	Rubber	EXHAUST SEAL	AUSPUFFDICHTUNG	JOINT D'ÉCHAPPEMENT	GUARNIZIONE DI SCARICO	SELLO DE EXTRACCIÓN
7	HH11170	Rubber	O-RING 1AP48	O-RING 1AP48	JOINT TORIQUE 1AP48	O-RING 1AP48	ANILLO TÓRICO 1AP48
8	CN37216	Polyacetal	HEAD VALVE GUIDE	DRUCKVENTILFÜHRUNG	GUIDAGE DE LA SOUPAPE PRINCIPALE	GUIDA DELLA VALVOLA PRINCIPALE	GUÍA DELA VÁLVULA PRINCIPAL
9	KK23934	Stainless steel	COMPRESSION SPRING 3934	DRUCKFEDER 3934	RESSORT À PRESSION 3934	MOLLA DI COMPRESSIONE 3934	MUELLE DE COMPRESIÓN 3934
10	HH11138	Rubber	O-RING 1AP20	O-RING 1AP20	JOINT TORIQUE 1AP20	O-RING 1AP20	ANILLO TÁRICO 1AP20
11	CN37217	Polyacetal	HEAD VALVE PISTON	KOPFVENTILKOLBEN	PISTON DE CLAPET DE TÊTE	STANTUFFO VALVOLA DI MANDATA	EMBOLO VÁLVULA DEL CABEZAL
12	HH12108	Rubber	O-RING 1AG60	O-RING 1AG60	JOINT TORIQUE 1AG60	O-RING 1AG60	ANILLO TÓRICO 1AG60
13	CN35060	Polyacetal	CYLINDER RING	ZYLINDERRING	ANNEAU DE CYLINDRE	ANELLO CILINDRO	ANILLO DE CILINDRO
14	CN34682	Urethane	CYLINDER SEAL	ZYLINDERDICHTUNG	JOINT DE CYLINDRE	GUARNIZIONE DEL CILINDRO	SELLO DEL CILINDRO
15	HH19165	Rubber	O-RING 1A2.6x46.5	O-RING 1A2.6x46.5	JOINT TORIQUE 1A2.6x46.5	O-RING 1A2.6x46.5	ANILLO TÓRICO 1A2.6x46.5
16	CN35131	Rubber	CHECK VALVE	RÜCKSCHLAGVENTIL	CLAPET ANTI-RETOUR	VALVOLA DI NON RITORNO	VÁLVULA DE RETENCIÓN
17	TA16998	Aluminum	CYLINDER	ZYLINDER	CYLINDRE	CILINDRO	CILINDRO
18	HH11807	Rubber	O-RING 1AP38	O-RING 1AP38	JOINT TORIQUE 1AP38	O-RING 1AP38	ANILLO TÓRICO 1AP38
19	TA70278	Magnesium, Steel	MAIN PISTON UNIT	ARBEITSKOLBEN KOMPL.	PISTON DE TRAVAIL COMPLET	GRUPPO STANTUFFO OPERATORE	EMBOLO DE TRABAJO COMPL.
20	TA17016	Rubber	BUMPER	STOSSDÄMPFER	AMORTISSEUR	AMMORTIZZATORE	AMORTIGUADOR
21	TA17017	Steel	NOZZLE	DÜSE	BUSE	UGELLO	TOBERA
22	TA18506	Aluminum	FRAME	GEHÄUSE	BÔTIER	ALLOGGIAMENTO	CARCASA
23	TA81112		FRAME UNIT	GEHÄUSE KOMPL.	BÔTIER COMPLET	GRUPPO ALLOGGIAMENTO	CARCASA COMP.
24	TA18515	Polyethylene terephthalate	LABEL "A"	TYPENSCHILD "A"	PRAQUE SIGNALÉTIQUE "A"	TARGHETTA "A"	PLACA DE CARACTERÍSTICAS "A"
25	TA18516	Polyethylene terephthalate	LABEL "B"	TYPENSCHILD "B"	PRAQUE SIGNALÉTIQUE "B"	TARGHETTA "B"	PLACA DE CARACTERÍSTICAS "B"
26	TA18688	Steel	NOSE	NAGLERNASE	NEZ DE CLOUEUR	PUNTA SPARACHIODI	PICO DEL CLAVADOR
27	TA18523	Steel	WEAR CHIP	ABNUTZUNGSSPAN	COPEAU D'USURE	TRUCIOLO DI USURA	VIRUTA DE DESGASTE
28	AA22207	Steel	SCREW M4x5	SCHRAUBE M4x5	VIS M4x5	VITE 4x5	TORNILLO M4x5
29	TA18509	Steel	DRIVER GUIDE "B"	NAGELTREIBERFÜHRUNG "B"	GUIDAGE DE CHASSOR DE POINTES "B"	GUIDA SPINGI-CHIODI "B"	GUÍA CLAVADOR "B"
30	TA70256	Stainless steel, Steel	LATCH UNIT	VERSCHLUSS KOMPL.	FERMETURE COMPLET	GRUPPO CHIUSURA	CIERRE COMP.
31	FF21275	Steel	ROLL PIN 4x16	ROLLENBOLZEN 4x16	TOURILLON DE CYLINDRE 4x16	PERNO DI ROTOLAMENT 4x16	PERNO DE RODILLO 4x16
32	TA18508	Steel	DRIVER GUIDE "A"	NAGELTREIBERFÜHRUNG "A"	GUIDAGE DE CHASSOR DE POINTES "A"	GUIDA SPINGI-CHIODI "A"	GUÍA CLAVADOR "A"
33	BB40465	Steel	SCREW M6x45	SCHRAUBE M6x45	VIS 6x45	VITE 6x45	TORNILLO M6x45
34	FF21611	Steel	ROLL PIN 3x32	ROLLENBOLZEN 3x32	TOURILLON DE CYLINDRE 3x32	PERNO DI ROTOLAMENT 3x32	PERNO DE RODILLO 3x32
35	CN35074	Nylon	TRIGGER LOCK DIAL	BETÄTIGUNGSSPERREKNOPF	DISQUE DE BLOCAGE DE LA COMMANDE	DISCO DI SICURA GRILLETTO	DISCO BLOQUEO DE ACCIONAMIENTO
36	KK23507	Stainless steel	COMPRESSION SPRING 3507	DRUCKFEDER 3507	RESSORT À PRESSION 3507	MOLLA DI COMPRESSIONE 3507	MUELLE DE COMPRESIÓN 3507
37	TA17007	Steel	CONTACT ARM A	KONTAKTARM "A"	BARRE DE CONTACT A	BRACCIO DI CONTATTO "A"	BRAZO DE CONTACTO "A"
38	TA17008	Steel	CONTACT ARM B	KONTAKTARM "B"	BARRE DE CONTACT B	BRACCIO DI CONTATTO "B"	BRAZO DE CONTACTO "B"
39	BB40467	Steel	SCREW M5x6	SCHRAUBE M5x6	VIS M5x6	VITE 5x6	TORNILLO M5x6
40	TA17001	Nylon	CONTACT ARM GUIDE	KONTAKTARMFÜHRUNG	GUIDE DE LA BARRE DE CONTACT	GUIDA BRACCIO DI CONTATTO	GUÍA BRAZO DE CONTACTO
41	KK23807	Stainless steel	COMPRESSION SPRING 3807	DRUCKFEDER 3807	RESSORT À PRESSION 3807	MOLLA DI COMPRESSIONE 3807	MUELLE DE COMPRESIÓN 3807
42	KK23282	Stainless steel	COMPRESSION SPRING 3282	DRUCKFEDER 3282	RESSORT À PRESSION 3282	MOLLA DI COMPRESSIONE 3282	MUELLE DE COMPRESIÓN 3282
43	CC49409	Steel	NUT M5 "T"	MUTTER M5 "T"	ECROU M5 "T"	DADO M5 "T"	TUERCA M5 "T"
44	CN35075	Nylon	TRIGGER LOCK LEVER	BETÄTIGUNGSSPERREHEBEL	LEVIER DE BLOCAGE DE LA COMMANDE	LEVA DI SICURA GRILLETTO	PALANCA BLOQUEO DE ACCIONAMIENTO
45	TA17032	Aluminum	END CAP	ABSCHLUSSKAPPE	CAPOT DE RECOUVREMENT	CAPPUCCIO DI CHIUSURA	CAPERUZA DE CIERRE
46	HH12118	Rubber	O-RING 1AG35	O-RING 1AG35	JOINT TORIQUE 1AG35	O-RING 1AG35	ANILLO TÓRICO 1AG35
47	TA17024	Nylon	FILTER "A"	FILTER "A"	FILTRE "A"	FILTRO "A"	FILTRO "A"
48	HH11125	Rubber	O-RING 1AP12	O-RING 1AP12	JOINT TORIQUE 1AP12	O-RING 1AP12	ANILLO TÓRICO 1AP12
49	CN31323	Polyacetal	TRIGGER VALVE HOUSING	BETÄTIGUNGSVENTILGEHÄUSE	CHAPELLE DE SOUPAPE DE COMMANDE	ALLOGGIAMENTO VALVOLA DI AZIONAMENTO	CARCASA VÁLVULA DE ACCIONAMIENTO
50	HH11119	Rubber	O-RING 1AP6	O-RING 1AP6	JOINT TORIQUE 1AP6	O-RING 1AP6	ANILLO TÓRICO 1AP6



Recycled paper is used for this manual and its recyclable.

- The content of this manual might be changed without notice for improvement.
- Änderungen der Betriebsanleitung zum Zwecke der Verbesserung ohne Ankündigung vorbehalten.
- Le contenu de ce manuel est sujet à modification sans préavis à des fins d'amélioration.
- I contenuti di questo manuale possono essere cambiati senza preavviso per motivi di miglioramento del prodotto.
- El contenido de este manual puede ser cambiado sin noticia previa para mejoramiento.

- The specifications and design of the products in this manual will be subject to change without advance notice due to our continuous efforts to improve the quality of our products.
- Änderungen bei technischen Daten und Design der Produkte in diesem Handbuch im Sinne der Produktverbesserung bleiben vorbehalten.
- Les caractéristiques et la conception des produits mentionnés dans ce manuel sont sujettes à des modifications sans préavis en raison de nos efforts continus pour améliorer la qualité de nos produits.
- Le caratteristiche e la concezione dei prodotti menzionati in questo manuale sono soggette a modifiche senza preavviso a causa dei nostri sforzi continui per migliorare la qualità dei nostri prodotti.
- Las características y la concepción de los productos mencionados en este manual están sujetas a modificaciones sin preaviso debido a nuestros esfuerzos continuos para mejorar la calidad de nuestros productos.



MAX EUROPE GMBH

OSTSTRASSE 22, 40211
DÜSSELDORF, GERMANY
TEL: +49-211-9365300
FAX: +49-211-93653017

MAX EUROPE BV

Camerastraat 19
1322 BB Almere The Netherlands
Phone: +31-36-546-9699
FAX: +31-36-536-3985

www.max-ltd.co.jp/int/ (GLOBAL Site)

www.max-europe.com (EUROPE Site)

★080306-00/02